

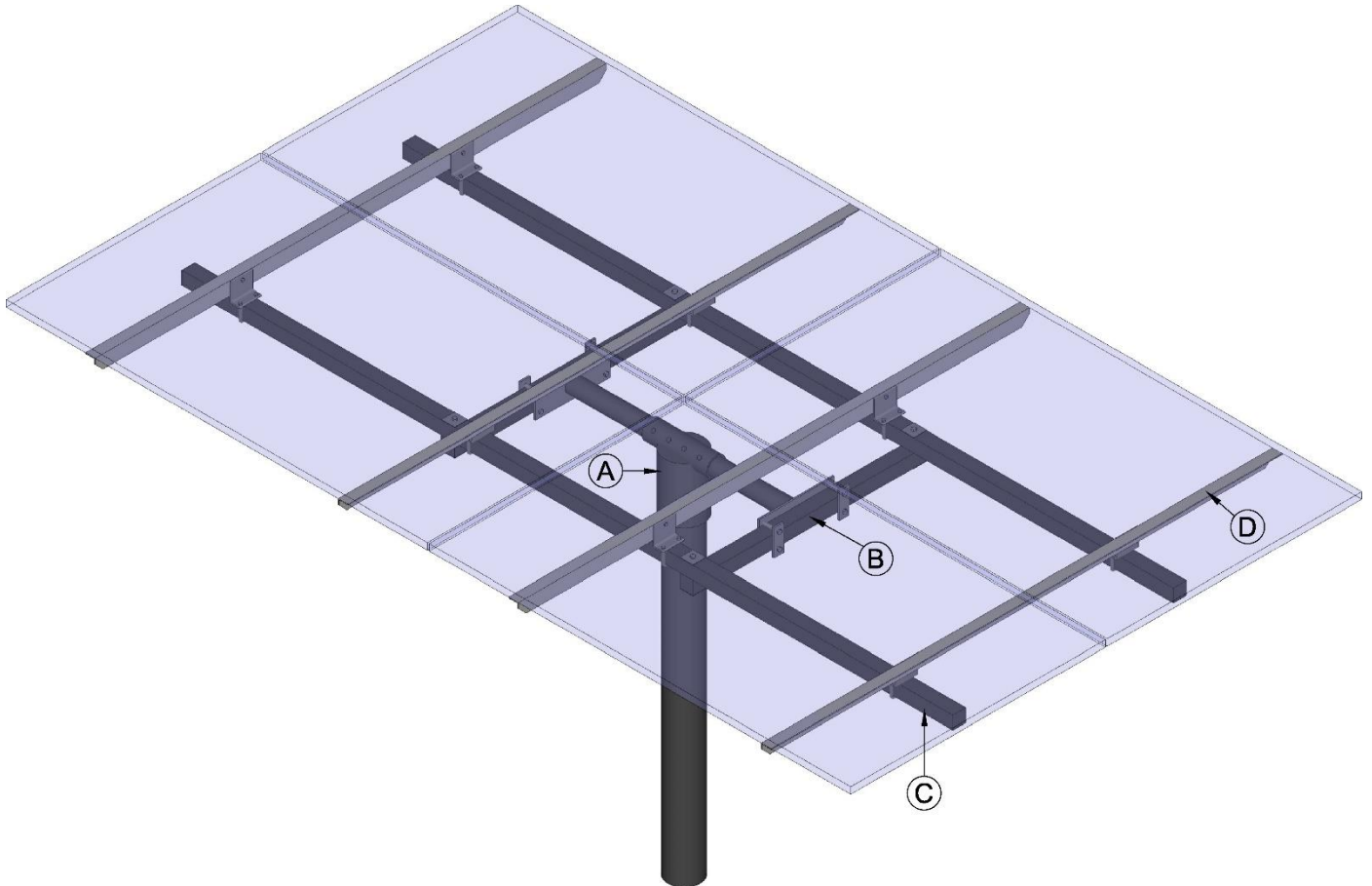

## Top of Pole Mount Assembly Instructions



### **UPM 6X**

Standard stock tee socket sized for 5" schedule 40 or 80 pipe

- A. **TEE SOCKET:** 6" O.D. PIPE SOCKET TO FIT OVER 5" SCHEDULE 40 OR 80 STEEL PIPE
- B. **CROSS PIECE:** 2" X 2" X 1/8", LENGTH IS 38", SQ. TUBE – 2 PLACES
- C. **LONGITUDINAL:** 2" X 2" X 1/8", LENGTH DEPENDENT ON MODULE USED, SQ. TUBE - 2 PLACES
- D. **ALUMINUM RAILS:** 2" X 1-1/2" X 1/8" UNIVERSAL ALUMINUM T-SLOT EXTRUSION OR PUNCHED ALUMINUM ANGLE, LENGTH DEPENDENT ON MODULE USED – 4 PLACES

**Note:** Number of panels may vary, length of rail may vary.  
Rev. 12/17



**COMPONENTS FOR THIS MOUNT****Box #1**

(1) Tee Socket with Center Tube

**Box #2**

(2) Cross Pieces

(5) Hardware bags

Bag#1

- Bolts for attaching aluminum angle brackets to rails.
- Square head set bolts for Tee.

Bag#2

- Bolts and nuts for attaching crosspieces to longitudinals (use included square galvy washers with these).

Bag#3

- U-bolts for attaching aluminum angle brackets to longitudinals (use included aluminum angle brackets with these).

Bag#4

- Bolts and flat bar for attaching center tube end plates on Tee assembly to crosspieces.

Bag#5

- Instructions.
- SS bolts and nuts for attaching panels to aluminum rails.

Shrink wrapped to crosspieces

- Square galvy washers for crosspieces to longitudinals (use with bag #2).
- Aluminum angle brackets for longitudinals to rails (use with bag#1 and #3).

**Box #3**

(2) Longitudinals

**Box #4**

(4) Aluminum Rails

**RECOMMENDATIONS FOR DIMENSIONS OF POST HOLE FOR STANDARD INSTALLATION OF  
GENERAL SPECIALTIES MANUFACTURING UPM6X**

<b>Depth of Hole</b>	<b>Width of Square Hole / Cubic Yards of concrete needed</b>	<b>Diameter of Round Hole / Cubic Yards of concrete needed</b>
54"	24" / .66 CY	30" / .81 CY

Your building department may require the foundation for a PV array post mount to be designed by a structural engineer licensed in the state where the PV array is to be erected. This is required because failure of a post mount foundation may be a threat to the safety of people and property in its proximity. At a minimum, failure will result in costly damage to the PV modules. The foundation described here is suitable for most soil types, but no warranty of its suitability for your particular soil or wind conditions is offered or implied.

If you are unable to dig holes of these dimensions because you encounter bed rock or if you have very loamy or loose sandy soil, (get the recommendation of a soil engineer or building department), then you may have to seek a design for an alternative foundation construction.

For type and size of pole to install in concrete foundation, refer to chart below.

**RECOMMENDATIONS FOR POLE HEIGHT FOR  
GENERAL SPECIALTIES MANUFACTURING UPM6X**

We cannot guarantee a standard 1.67 safety factor if these recommendations are not observed. Since we cannot assess each customer's individual site and conditions, a professional installer and the local building department should be consulted for the safest and most effective installation.

<b>UPM Model</b>	<b>Post Size (sch = schedule, or thickness of pipe wall)</b>	<b>Max Pole Height above concrete Base w/array @ 45° tilt</b>	<b>Clearance between top of concrete and lowest point on array @ 45° tilt</b>	<b>Max Pole Height above concrete base w/array @ 60° tilt</b>	<b>Clearance between top of concrete and lowest point on array @ 60° tilt</b>	<b>Max Pole Height above concrete base w/array @ 90° tilt</b>	<b>Clearance between top of concrete and lowest point on array @ 90° tilt</b>
<b>UPM6X</b> Standard stock tee socket size 5"	5" sch 40 5 9/16" OD	7' 9"	5' 9"	6' 3"	3' 8"	5' 4"	2' 2"
	5" sch 80 5 9/16" OD	10' 9"	8' 9"	8' 9"	8' 9"	7' 6"	4' 4"

## ASSEMBLY INSTRUCTIONS

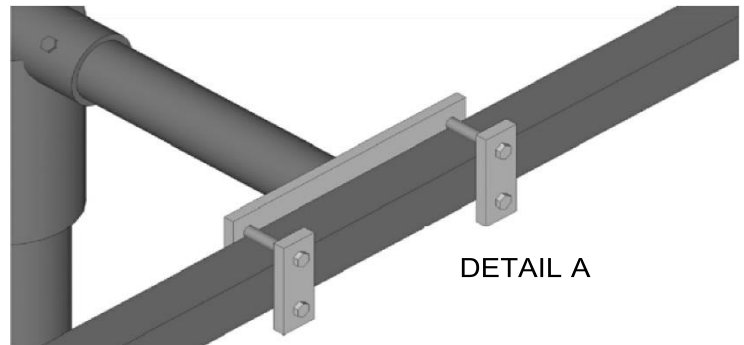
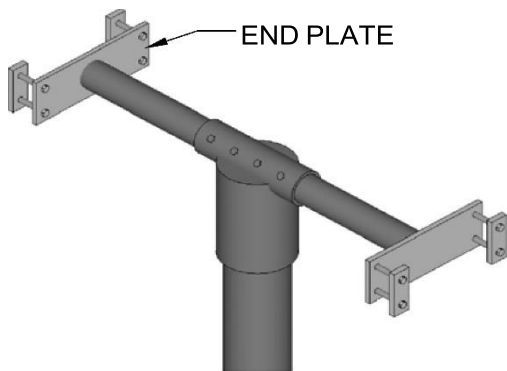

Finger tighten onto "Tee" end plates the aluminum flat bar and straight 1/2" bolts. Place entire "Tee" assembly on top of post. The aluminum flat bar and straight 1/2" bolts are shown in Detail "A". Tighten both set bolts and the four bolts on the top of the "Tee".

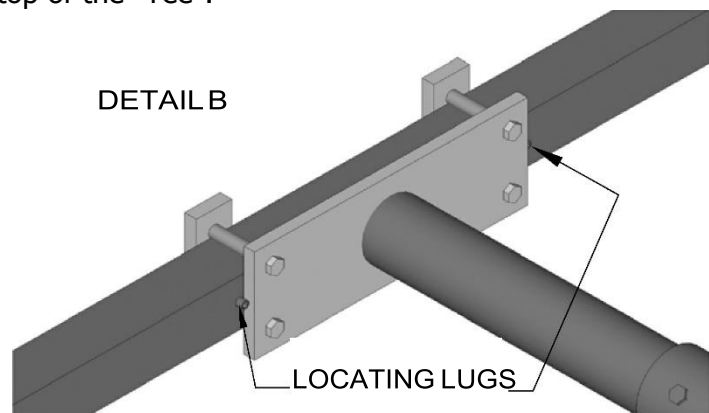

Slide cross pieces into flat bar arrangement. Make sure locating lugs on cross pieces are facing in. See Detail "B" of locating lugs.

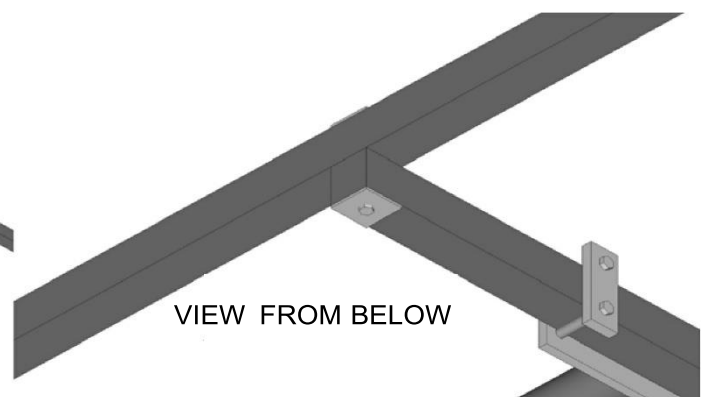
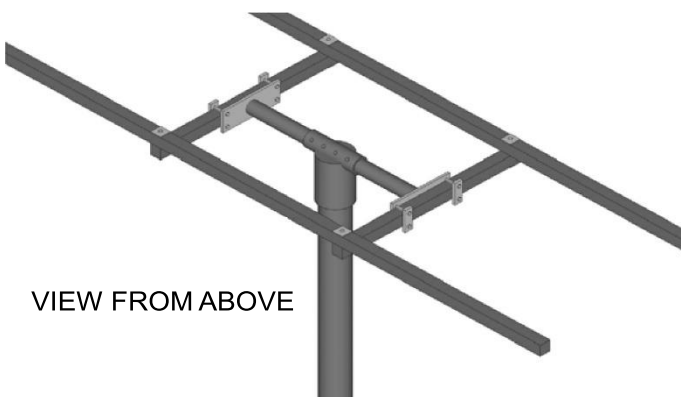

Place longitudinal tubes on top of cross pieces and bolt with square washers top and bottom as shown.

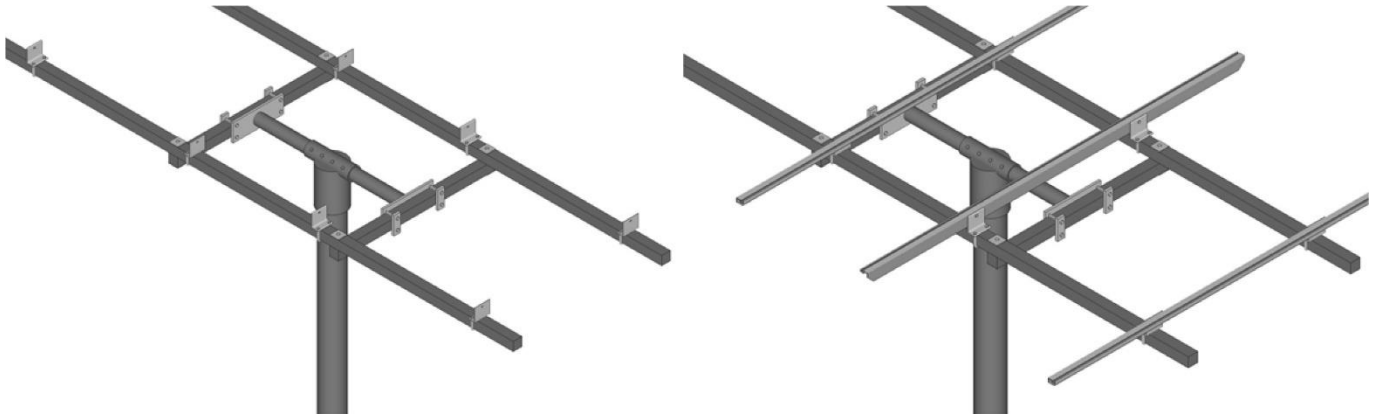

Attach aluminum angle brackets to longitudinals with smaller square U-Bolts and whiz flange nuts (bag #3). Oppose aluminum angle brackets as shown. Some mounts come with aluminum angle rails with punched holes for bolting on panels, and some come with aluminum extrusions which allow for panel attachment bolts or clips to slide in the "t-slot".

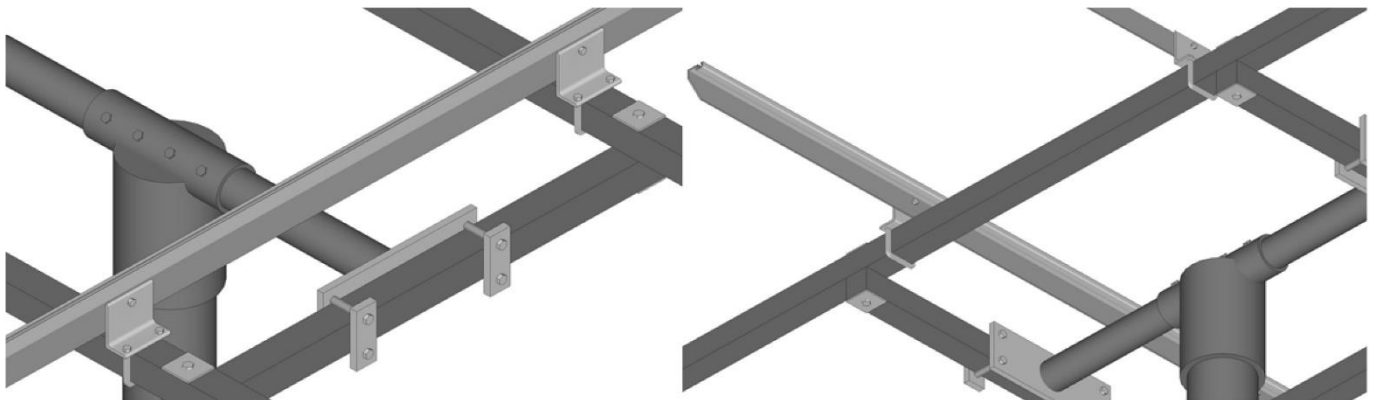

Attach aluminum rails as shown. If rail ends are marked "TOP", align them to the same end.

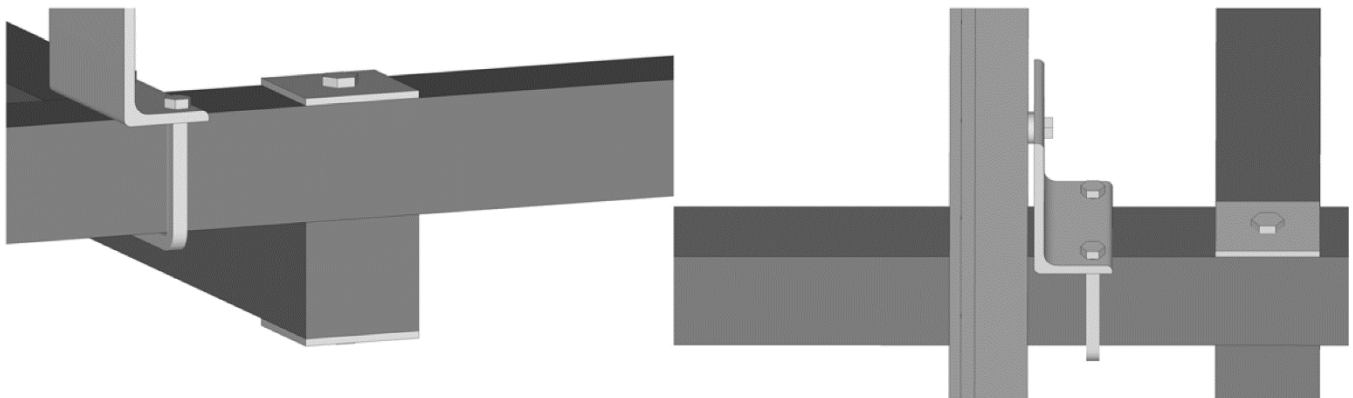

**General view of assembly.** When fastening panels to rails, place first panels at end of rails marked "TOP" and work down until all panels are in place with bolts finger tight. Cross measure array for square, check to see that all spaces (approx.  $\frac{1}{4}$ " ) between panels are equal, **then tighten all bolts.**

## PANEL RAIL/BRACKET LOCATION INSTRUCTIONS

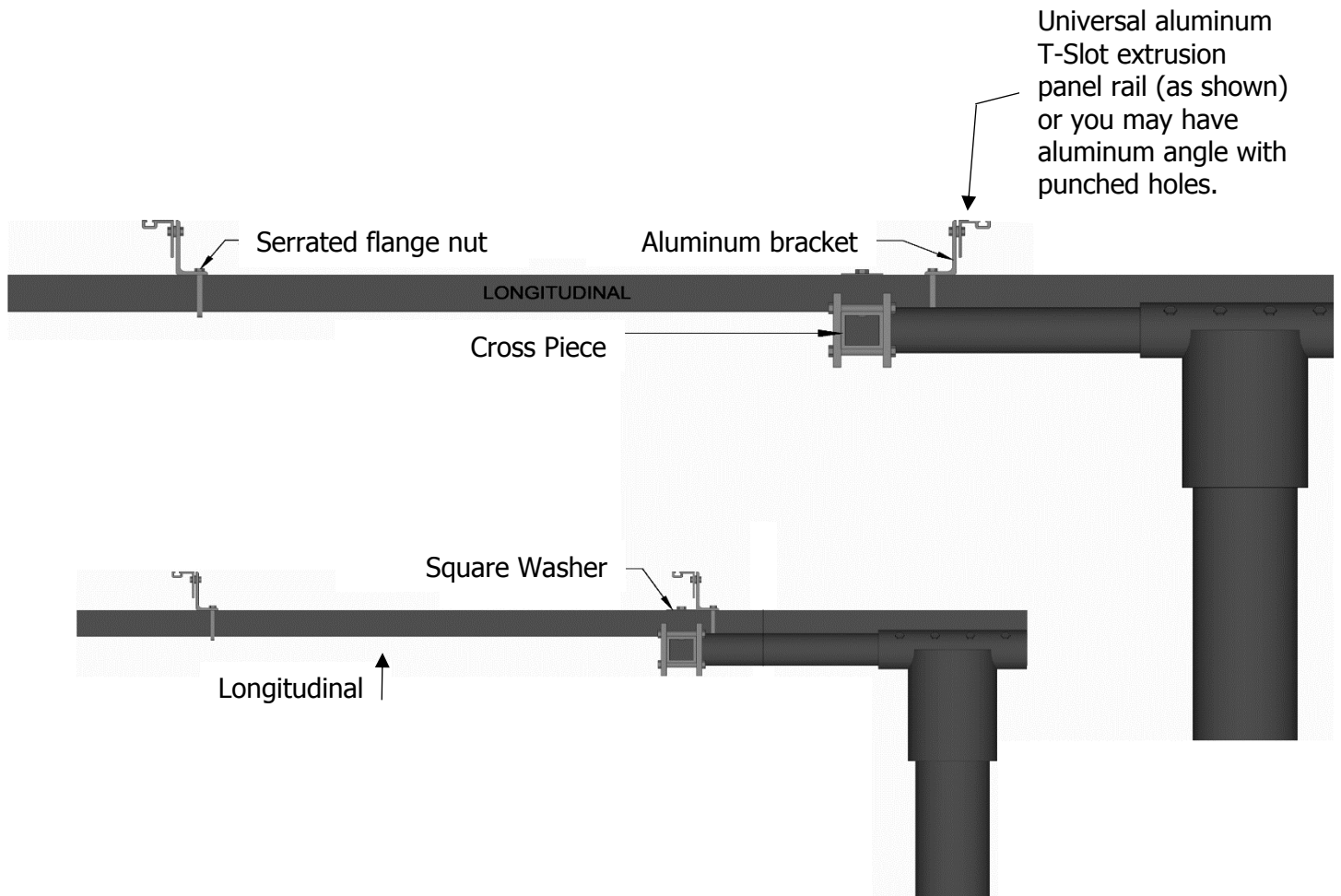

Bracket orientation in most installations is generally opposed to one another as in top picture. It may be necessary to have brackets facing in same direction as in bottom picture, if panel size is such that you need to do this to maintain a  $\frac{1}{4}$ " gap between panel ends on centerline.

**NOTE:** Leave  $\frac{5}{16}$ " serrated flange nuts *slightly loose* until all panels are attached and square to one another. **Then finish tightening the nuts.**

## INSTRUCTIONS FOR ATTACHING SOLAR PANEL TO MOUNTING RAILS

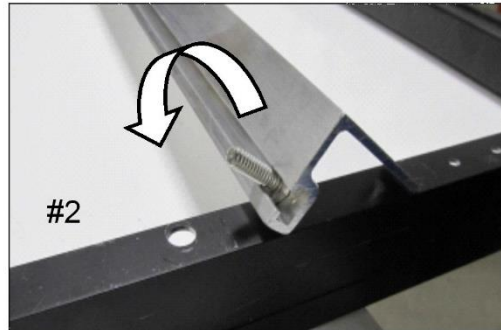

**For T-Slot Rails:** Lay T-Slot rails across the short axis of the panel as shown in Photo #1. Slide stainless bolts into T-slot of rail and position so they are opposite to the mounting holes on the frame of the panel as shown in Photo #2. Then roll the rails over so the bolts slip into the holes on the panel frame. Place the flange nut on your finger with the flange UP and thread onto the bolt from underneath as shown in Photo #3. Finger tighten.

**For Pre-Punched Angle Rails:** Attach panel rails to solar module across the width of the panel as in Photo #4. Make sure the part of the rail with the punched slots "toes-out" toward the ends of the panel. Insert the bolts in the holes provided from underneath facing out (Photo #5) and tighten on the flange nut. It is important that the flange nut bears against the rail and not the panel frame, Photo #6.

